

Service Schematics



RM-140



Introduction

Important:

This document is intended for use by authorized service centers only.

“Service Schematics” was created with focus on customer care.
The purpose of this document is to provide further technical repair information for NOKIA mobile phones on Level 3/4 service activities.
It contains additional information such as e.g. “Component finder”, “Frequency band table” or “Antenna switch table”.
The “Signal overview” page gives a good and fast overview about the most important signals and voltages on board.
Saving process time and improving the repair quality is the aim of this document.
It is to be used additionally to the service manual and other training or service information such as Service Bulletins.

All measurements were made using following equipment:

Nokia repair SW : Phoenix version 2006.34.2.156
Oscilloscope : Fluke PM 3380A/B
Spectrum Analyzer : Advanced R3162 with an analog probe
RF-Generator/GSM Tester : Rhode & Schwarz CMU 200
Multimeter : Fluke 73 Series II

While every endeavour has been made to ensure the accuracy of this document, some errors may exist. If the reader finds any errors, NOKIA should be notified in writing.

Please send E-Mail to: training.sace@nokia.com

A NEW FEATURE FOR ON-LINE USE

We have now linked those measurement points , which are related to the oscillograms shown on the signal overview page. As example: clicking on the measurement point guides you to the matching oscillogram on the signal overview page. The next click onto the now shown signal guides you to the related measurement point on the module. Finally, a third click , now onto the measurement point on the module, takes you back to the starting point inside the schematics.

Do you have further improvement ideas or would like to give us feedback?
Please send an email to: training.sace@nokia.com

Table of contents

Frontpage	1
AV connector, BETTY, USB	2
AVILMA,BTFM, SIM, Audio	3
OMAP, Camera, B-to-B connector	4
RAP3GS, Combo memory, Keyboard	5
UI Part	6
RF Part	7
Signal overview	8
Component finder	9

Copyright © NOKIA

This material , including documentation and any related computer programs is protected by copyright, controlled by NOKIA. All rights are reserved. Copying, including reproducing, modifying, storing, adapting or translating any or all of this material requires the prior written consent of NOKIA. This material also contains confidential information, which may not be disclosed to others without the prior written consent of NOKIA.

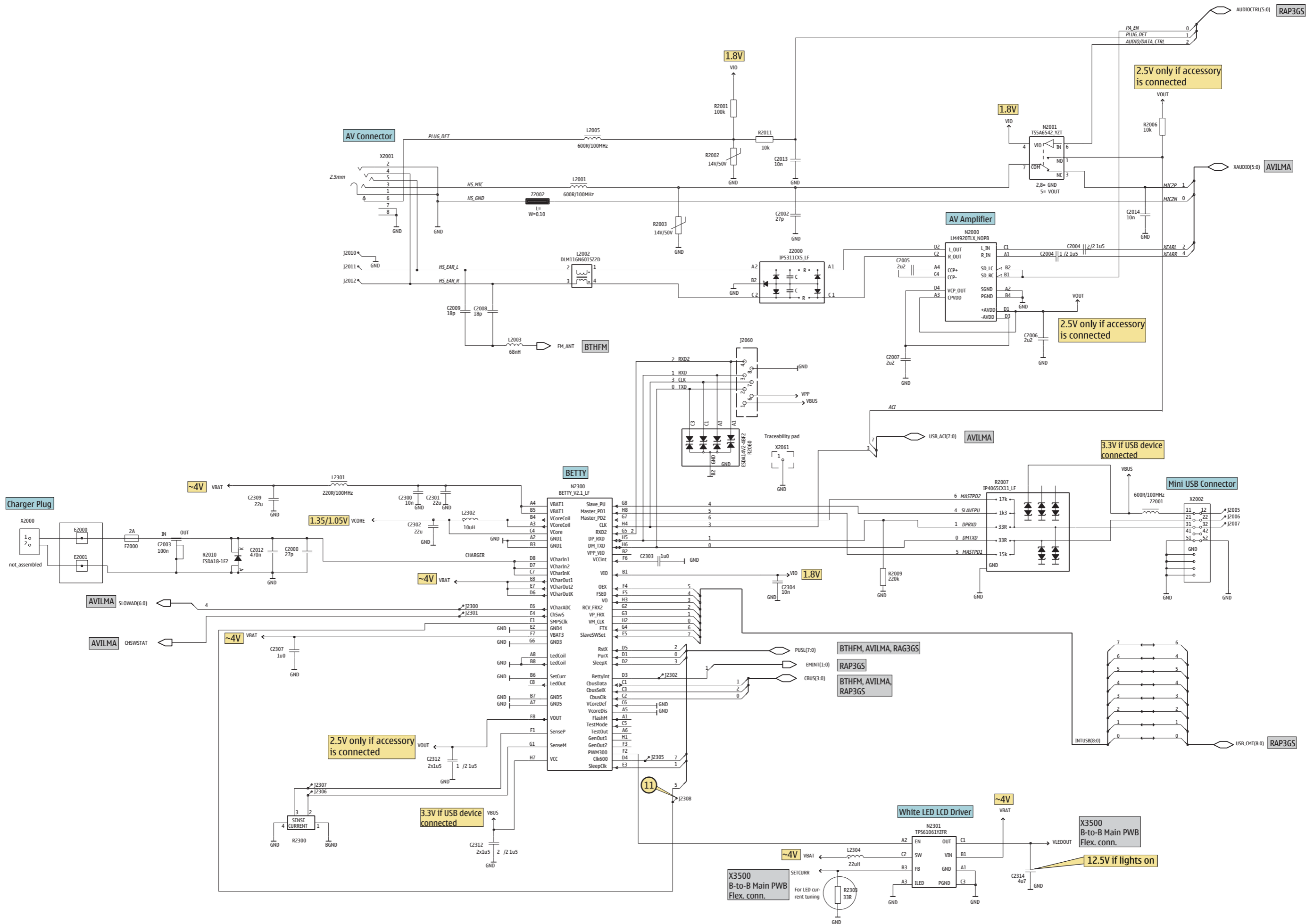

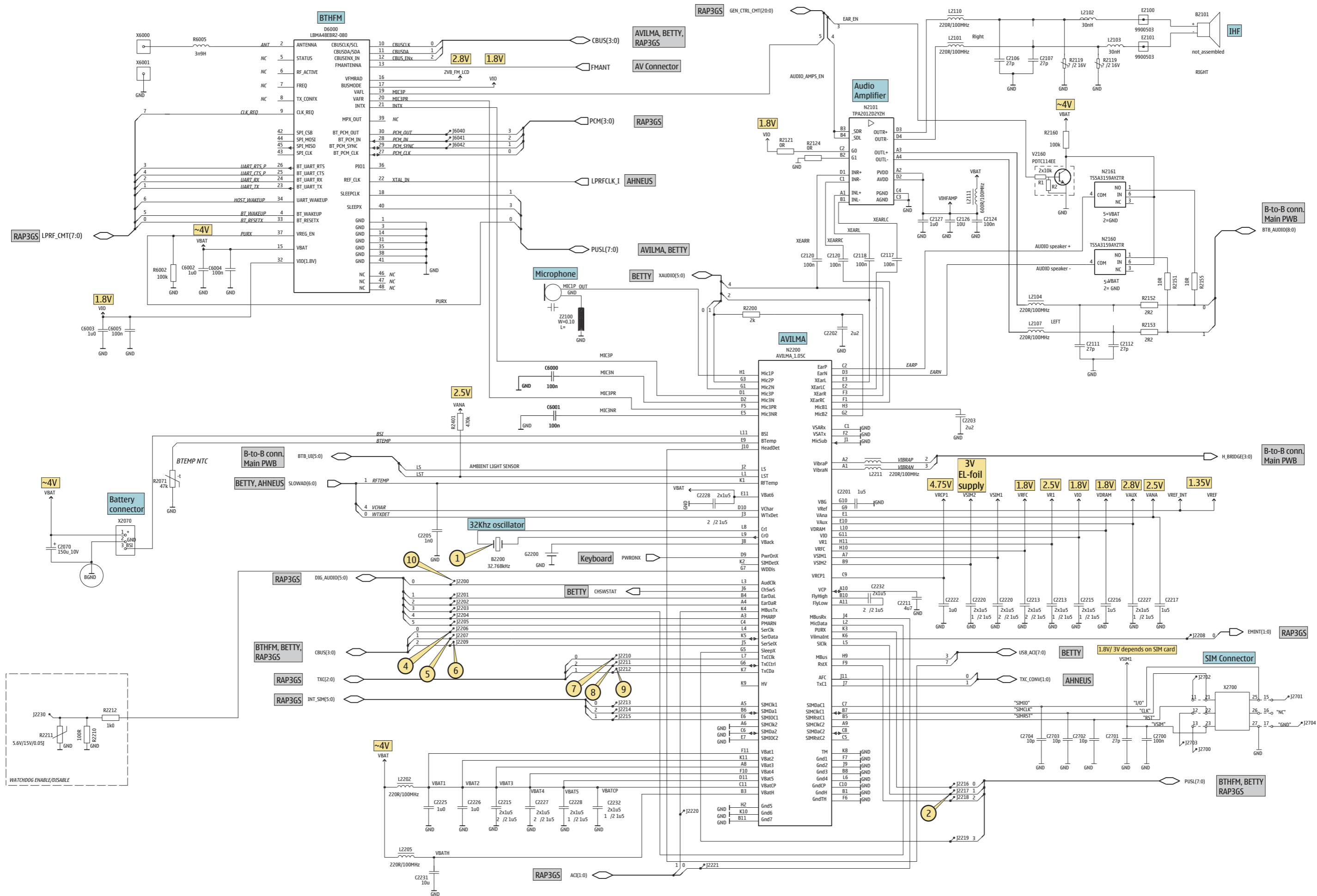

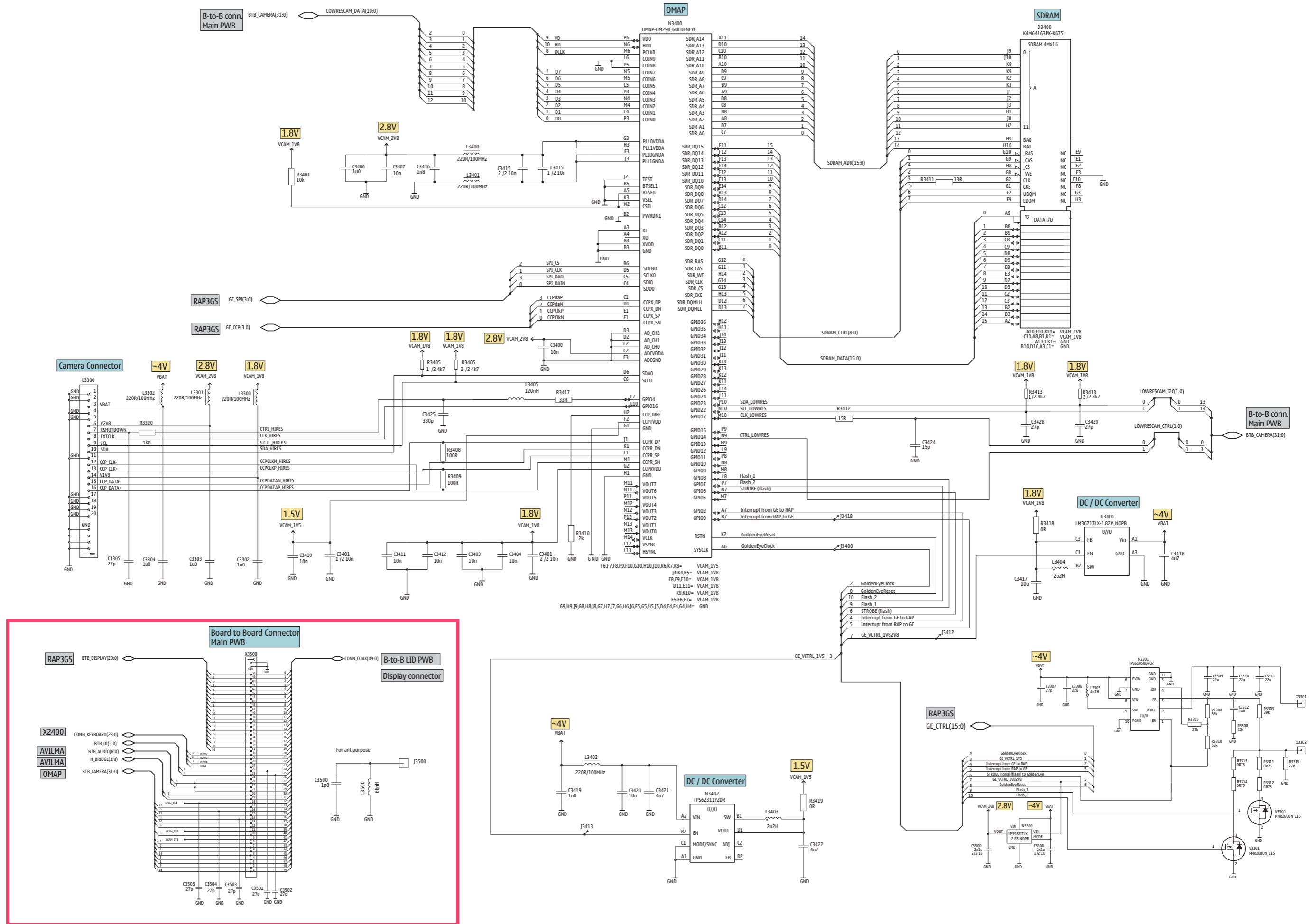

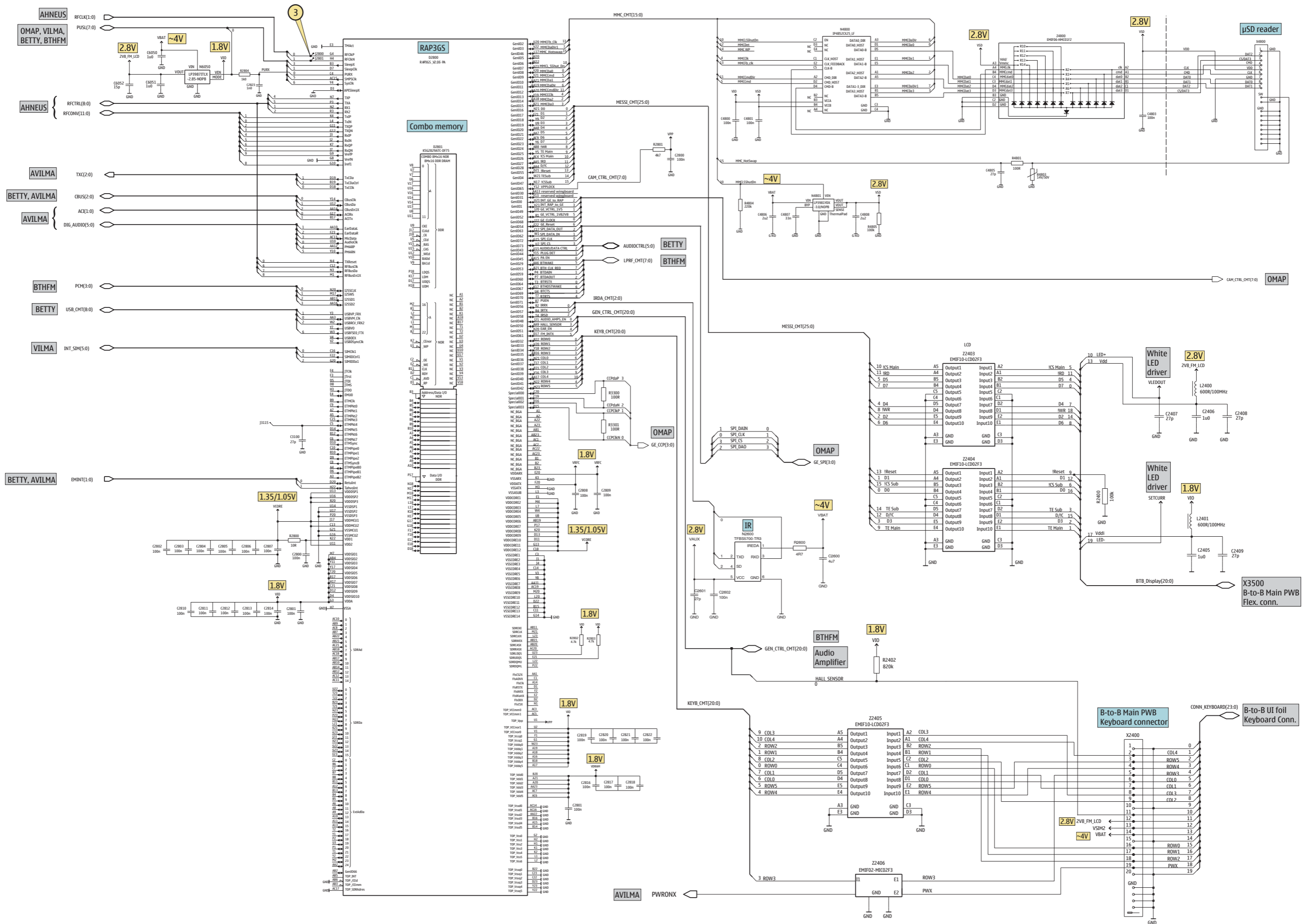

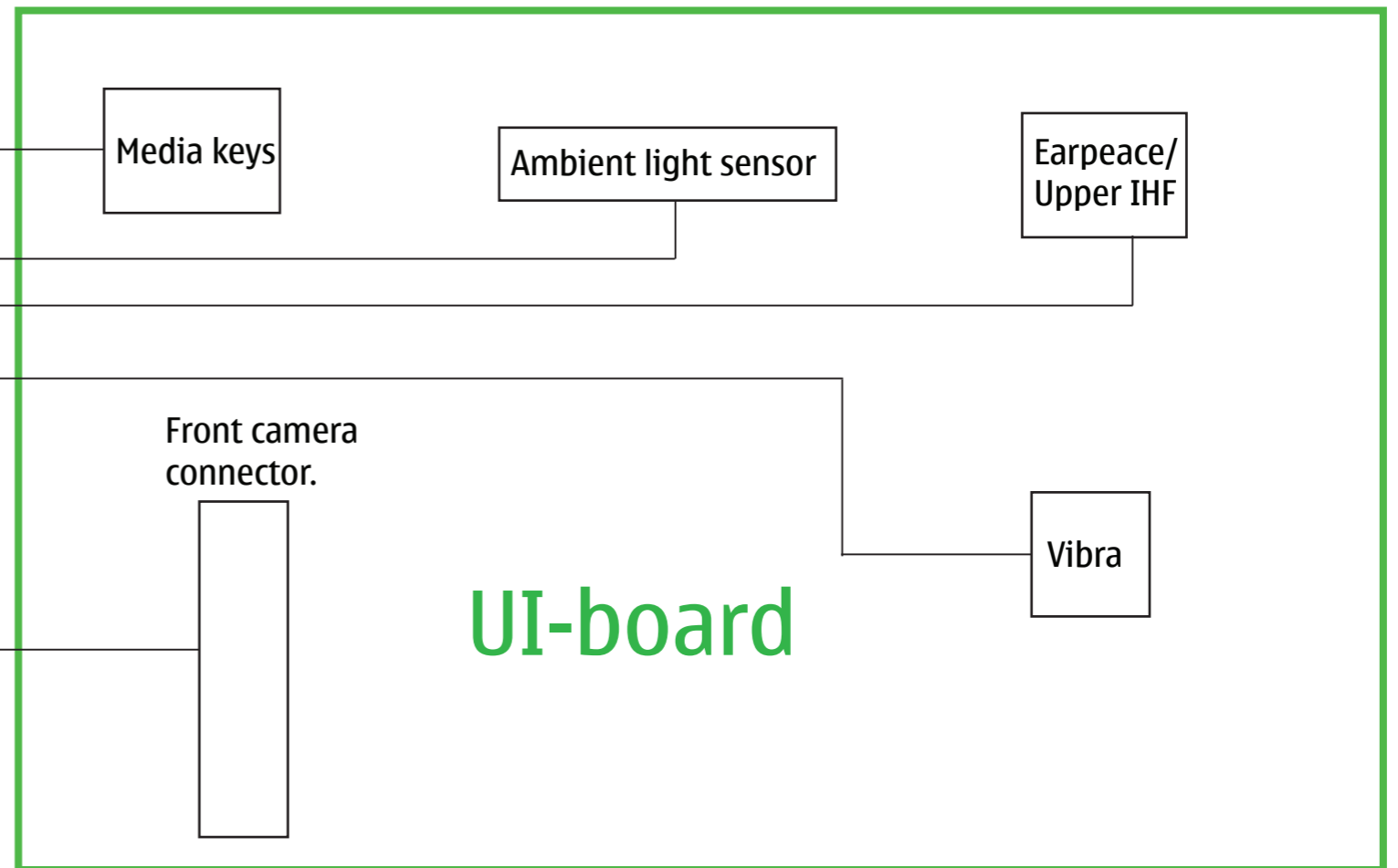
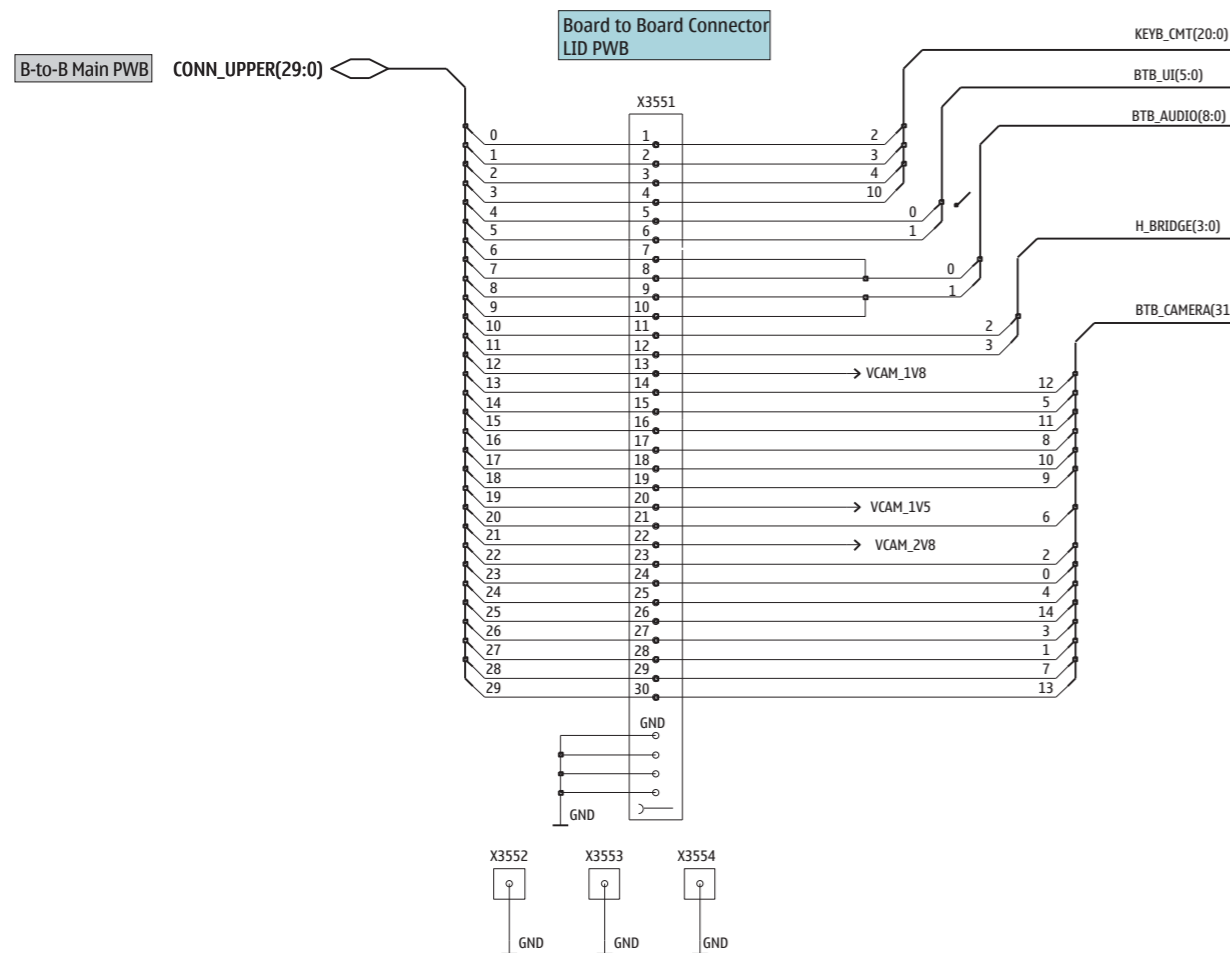
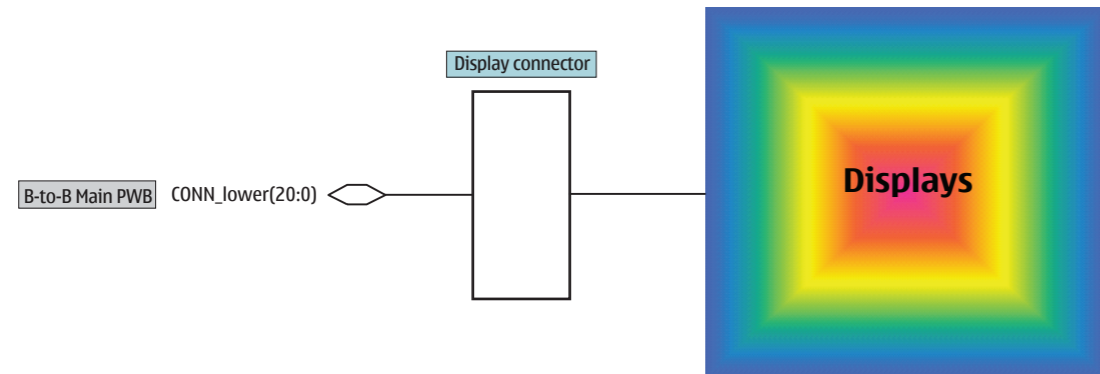
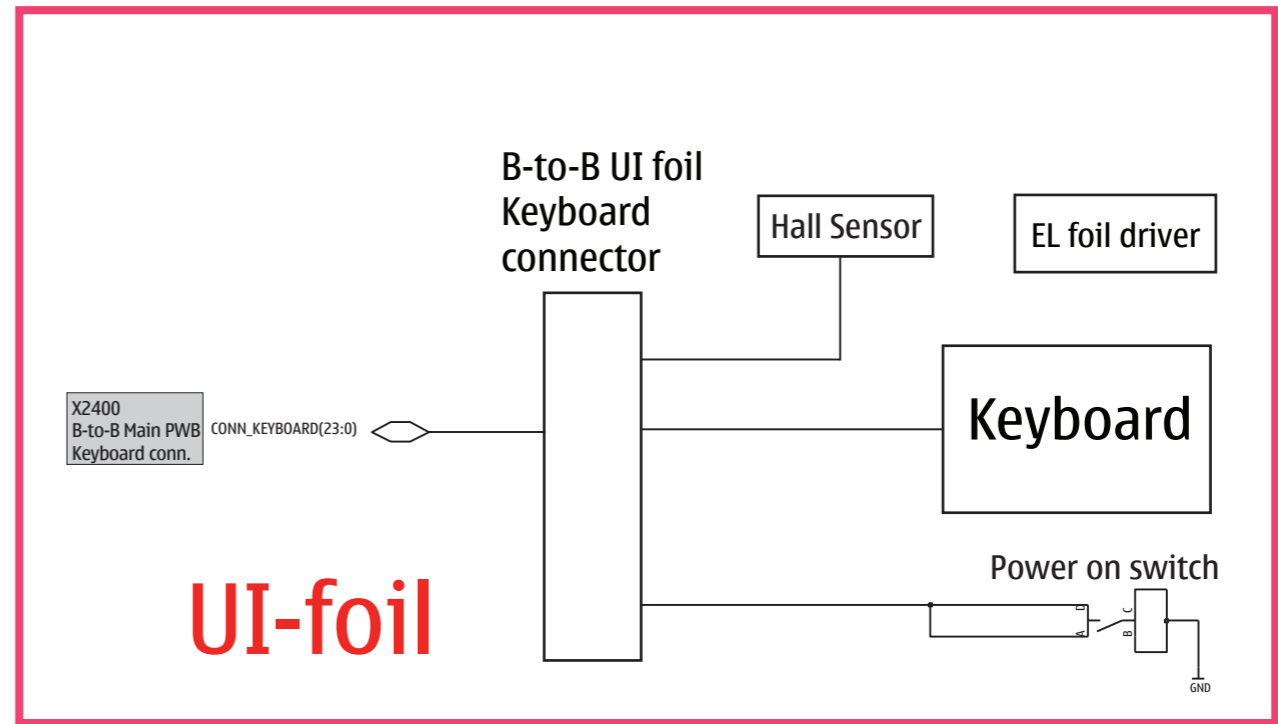
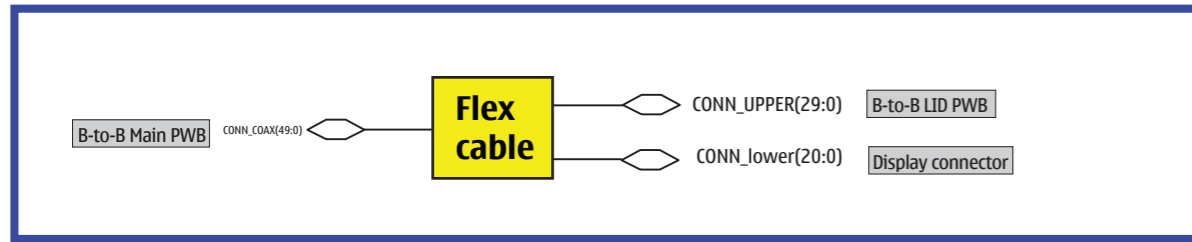

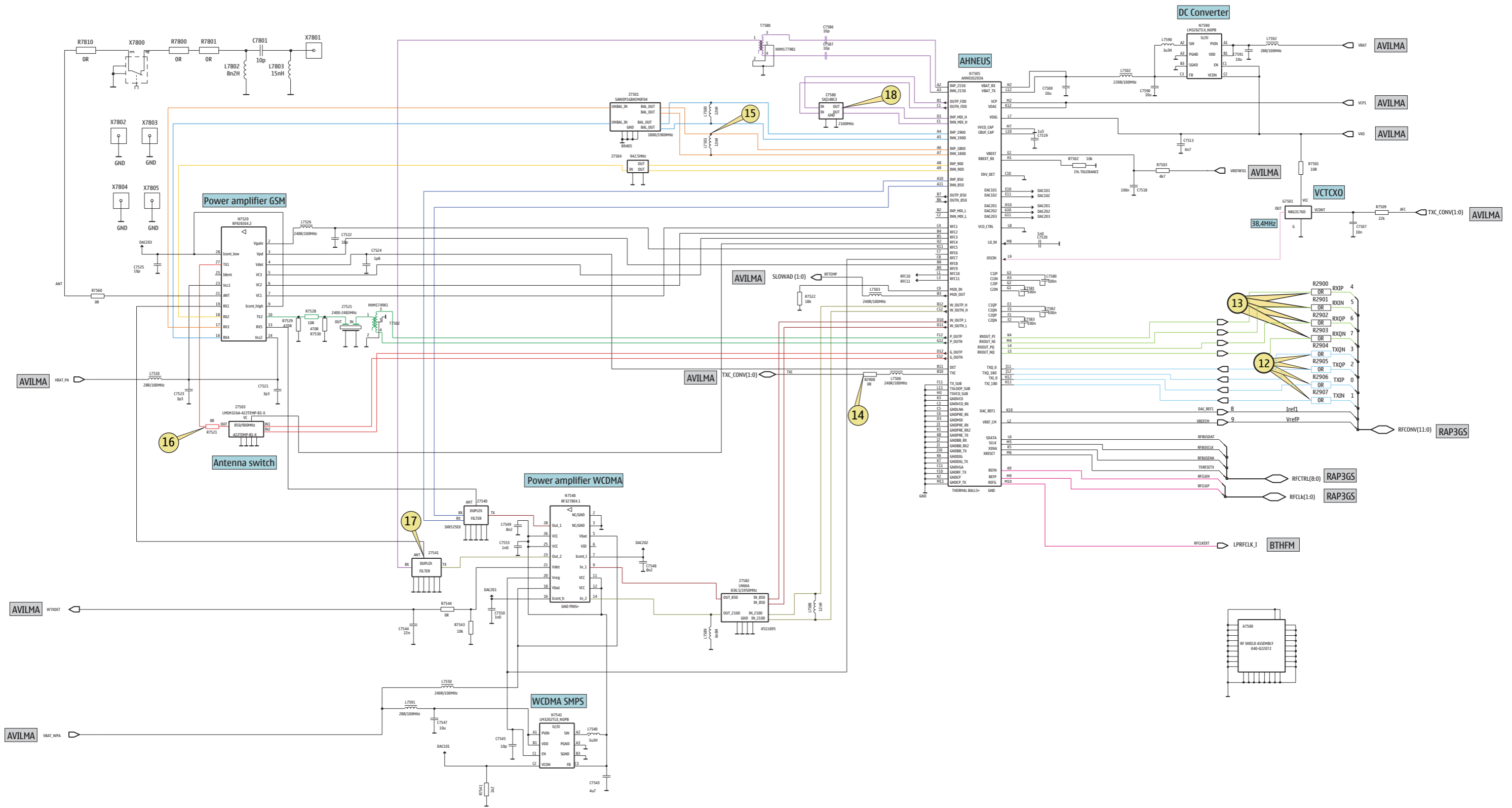

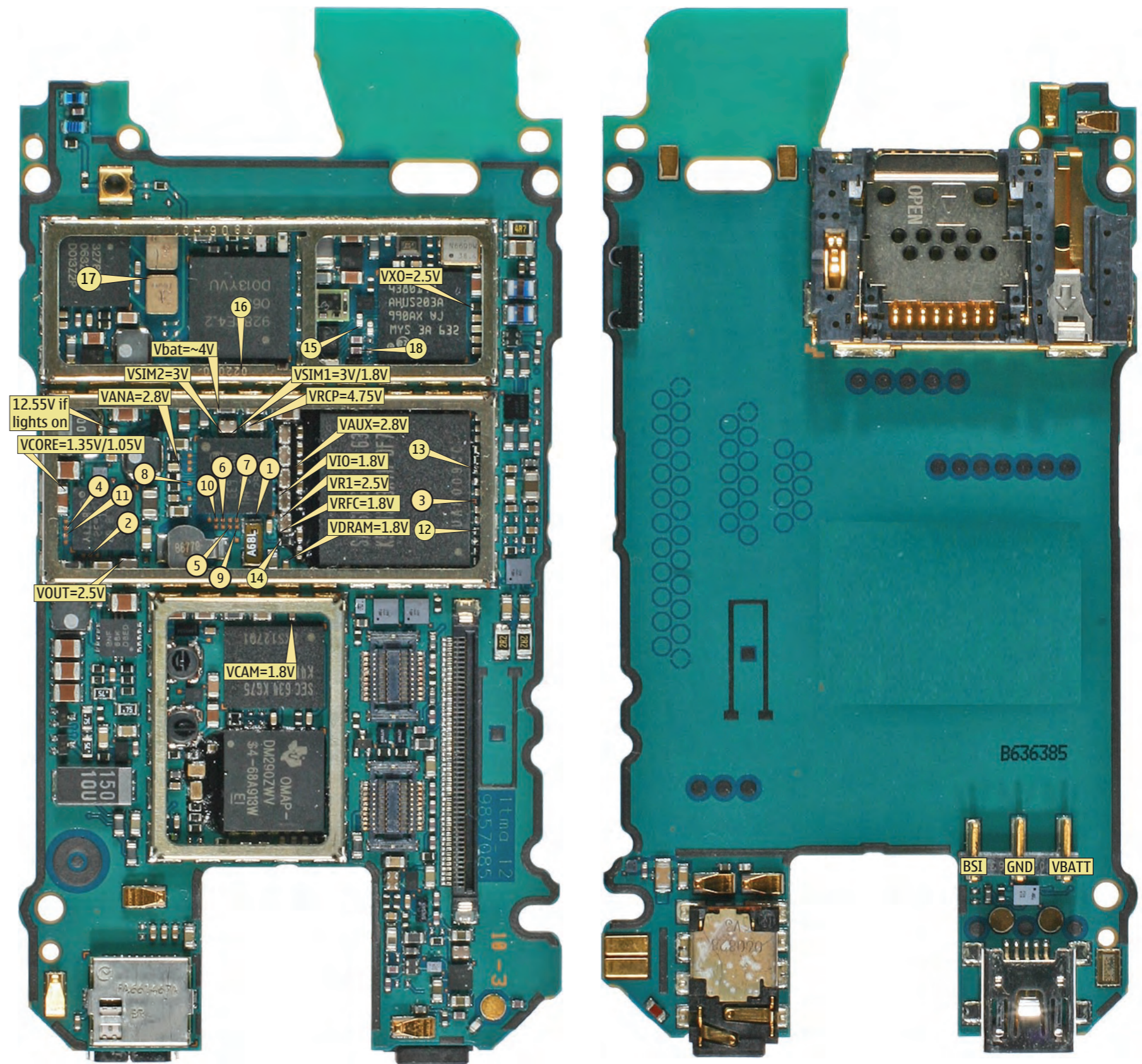
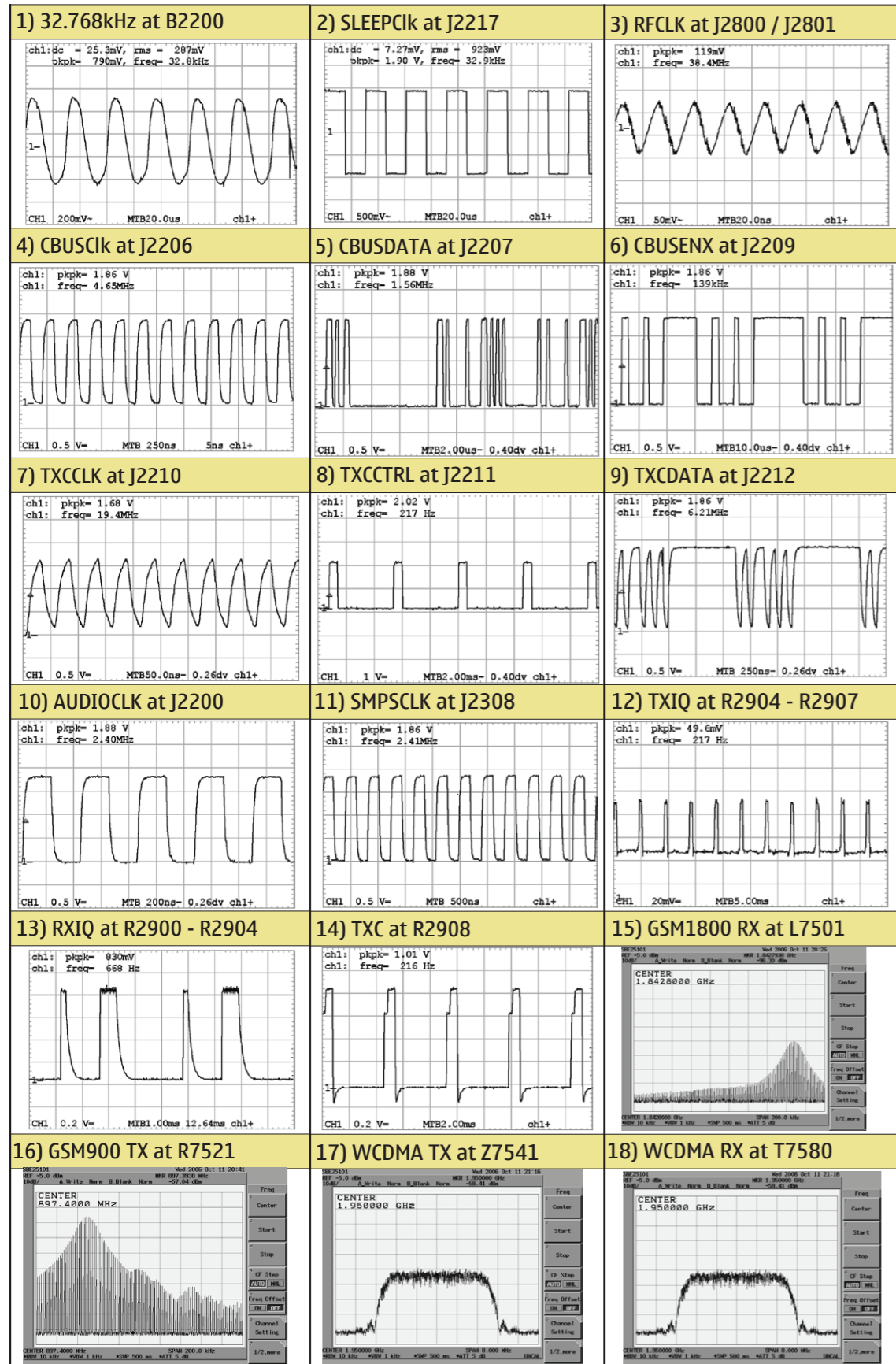

B	C2811	H8	C7524	G5	J3102	H8	N2200	I5	R3410	N4	
B2200	J5	C2812	J8	C7525	G5	J3103	H7	N2300	I2	R3411	M6
C	C2813	H6	C7543	F3	J3104	I7	N2301	H3	R3412	N6	
C2000	O9	C2814	H7	C7544	F2	J3105	I7	N2600	F9	R3413	N6
C2002	Q8	C2815	H8	C7545	F2	J3110	I8	N3300	O7	R3417	N3
C2003	O9	C2816	H6	C7547	F2	J3111	J8	N3301	K3	R3418	M4
C2004	P8	C2817	H8	C7548	F2	J3112	I7	N3400	N5	R3419	L3
C2005	Q8	C2818	J6	C7549	F3	J3113	I7	N3401	L4	R4801	D6
C2006	P8	C2819	H8	C7550	F2	J3114	J7	N3402	K4	R4803	D6
C2007	Q8	C2820	I8	C7553	E3	J3115	I7	N4800	E3	R4804	F2
C2008	Q7	C2821	J7	C7580	G8	J3116	I7	N4801	E2	R4805	E2
C2009	Q7	C2822	H6	C7581	G8	J3117	I7	N6050	M3	R6002	M2
C2012	O9	C2823	J8	C7582	G9	J3118	H7	N7505	F8	R6005	O8
C2013	P7	C3100	J8	C7583	G8	J3119	H7	N7520	F5	R7501	F8
C2014	O7	C3300	O7	C7586	G7	J3120	I7	N7540	E2	R7502	G8
C2070	N2	C3302	O7	C7587	F7	J3400	I6	N7541	G2	R7503	G7
C2106	F9	C3303	O8	C7590	E6	J3412	L4	N7590	E6	R7509	E8
C2107	G9	C3304	M8	C7591	E6	J3413	K4	R	R7521	G5	
C2111	G9	C3305	N8	C7801	C2	J3418	H6	R2001	O7	R7522	F7
C2112	H9	C3307	K2	D	J3500	Q9	R2002	P7	R7528	E5	
C2117	I9	C3308	K3	D2800	I7	J6040	H6	R2003	Q8	R7529	E5
C2118	I9	C3309	L2	D2801	I7	J6041	H6	R2006	P8	R7530	E5
C2119	I9	C3310	K2	D3400	L5	J6042	I6	R2007	P3	R7541	G2
C2120	I9	C3311	L2	D6000	Q3	L	R2009	P3	R7543	F2	
C2124	I9	C3312	L3	F	L2001	Q8	R2010	O9	R7544	F2	
C2126	I9	C3400	M4	F2000	Q9	L2002	Q7	R2011	O7	R7560	G3
C2127	I9	C3401	N4	G	L2003	P7	R2060	I2	R7800	D2	
C2201	I5	C3403	M5	G2200	J4	L2005	P7	R2071	O8	R7801	C2
C2202	H4	C3404	N5	G7501	E8	L2101	G9	R2119	F9	R7810	D3
C2203	I4	C3406	O5	J	L2102	F9	R2121	J9	T		
C2205	I4	C3407	O5	J2005	P4	L2103	F9	R2124	J9	T7502	E5
C2211	H5	C3410	N6	J2006	P3	L2104	H9	R2151	M7	T7580	G6
C2213	I5	C3411	K5	J2007	P2	L2107	H9	R2152	K9	V	
C2215	I5	C3412	M6	J2010	N7	L2110	G9	R2153	K9	V2160	M7
C2216	J5	C3415	M4	J2011	N8	L2111	H9	R2155	M7	V3300	L2
C2217	I4	C3416	N4	J2012	N8	L2202	H4	R2160	M7	V3301	M2
C2220	H4	C3417	L4	J2060	I3	L2205	H4	R2200	I4	X	
C2222	H5	C3418	L4	J2200	I4	L2211	N3	R2210	K7	X2001	Q8
C2225	J5	C3419	K5	J2201	H4	L2212	O3	R2211	K7	X2002	Q3
C2226	H5	C3420	K4	J2202	I6	L2301	H3	R2212	I4	X2061	Q2
C2227	I5	C3421	K4	J2203	I4	L2302	H2	R2300	J2	X2070	O3
C2228	H5	C3422	K4	J2204	H7	L2304	H3	R2303	H3	X2400	L7
C2231	H4	C3424	N6	J2205	H4	L2400	K8	R2400	K8	X2700	E5
C2232	H5	C3425	N4	J2206	I2	L2401	L8	R2401	H4	X3300	N7
C2300	H3	C3428	N6	J2207	I4	L3300	O7	R2402	L8	X3301	P3
C2301	I2	C3429	N6	J2208	I4	L3301	P7	R2600	E9	X3302	P3
C2302	I2	C3500	Q9	J2209	I4	L3302	M8	R2800	I6	X3500	M8
C2303	J2	C3501	N8	J2210	I5	L3303	K2	R2801	H7	X4800	E4
C2304	I2	C3502	N8	J2211	I4	L3400	M4	R2802	H7	X6000	O8
C2307	J3	C3503	O8	J2212	I5	L3401	M4	R2803	J6	X6001	O7
C2309	H3	C3504	O8	J2213	J7	L3402	K5	R2804	J8	X7800	D3
C2312	J3	C3505	P8	J2214	I6	L3403	L4	R2900	J8	X7801	C3
C2314	I3	C4800	F3	J2215	I4	L3404	M4	R2901	J8	X7802	C2
C2405	K9	C4801	E3	J2216	I2	L3405	N4	R2902	J8	X7803	Q7
C2406	K9	C4803	E3	J2217	J2	L3500	Q8	R2903	J8	X7804	O3
C2407	L8	C4805	E6	J2218	J5	L7500	F7	R2904	I8	X7805	Q2
C2408	L8	C4806	E2	J2219	J3	L7501	F7	R2905	I8	Z	
C2409	M8	C4807	F2	J2220	I4	L7502	E7	R2906	H8	Z2000	P8
C2600	E9	C4808	E2	J2221	I4	L7503	G7	R2907	H8	Z2001	P4
C2601	E9	C6000	P3	J2230	J7	L7506	E8	R2908	J5	Z2002	Q8
C2602	E9	C6001	P3	J2300	I4	L7510	E4	R3300	J6	Z2100	I4
C2700	F6	C6003	P4	J2301	J2	L7526	G6	R3301	J7	Z2403	J9
C2701	F6	C6004	P4	J2302	J3	L7540	G3	R3303	L2	Z2404	K7
C2702	E6	C6005	Q2	J2305	I3	L7550	F2	R3304	L3	Z2405	K7
C2703	E6	C6006	P3	J2306	J2	L7588	E7	R3305	L3	Z2406	K7
C2704	E3	C6050	M2	J2307	J2	L7589	E7	R3308	L2	Z4800	E3
C2800	I6	C6051	M3	J2308	J2	L7590	E6	R3310	L3	Z7501	F6
C2801	H8	C6052	M3	J2700	G6	L7591	G2	R3311	L2	Z7503	F6
C2802	H6	C7500	F8	J2701	G4	L7592	E6	R3312	L3	Z7504	F7
C2803	H8	C7507	E7	J2702	G5	L7802	C2	R3313	M2	Z7521	E5
C2804	H8	C7513	F8	J2703	G5	L7803	C2	R3314	M2	Z7540	E3
C2805	H6	C7518	G7	J2704	G4	N	R3315	L2	Z7541	F3	
C2806	I8	C7519	F8	J2800	I9	N2000	Q8	R3320	O8	Z7580	G6
C2807	J7	C7520	F8	J2801	I8	N2001	P8	R3401	N4	Z7582	E7
C2808	I8	C7521	G4	J2803	J2	N2101	H9	R3405	M5		
C2809	J6	C7522	F6	J3100	I8	N2160	M7	R3408	N4		
C2810	J6	C7523	E4	J3101	H8	N2161	M7	R3409	N4		

